

2023

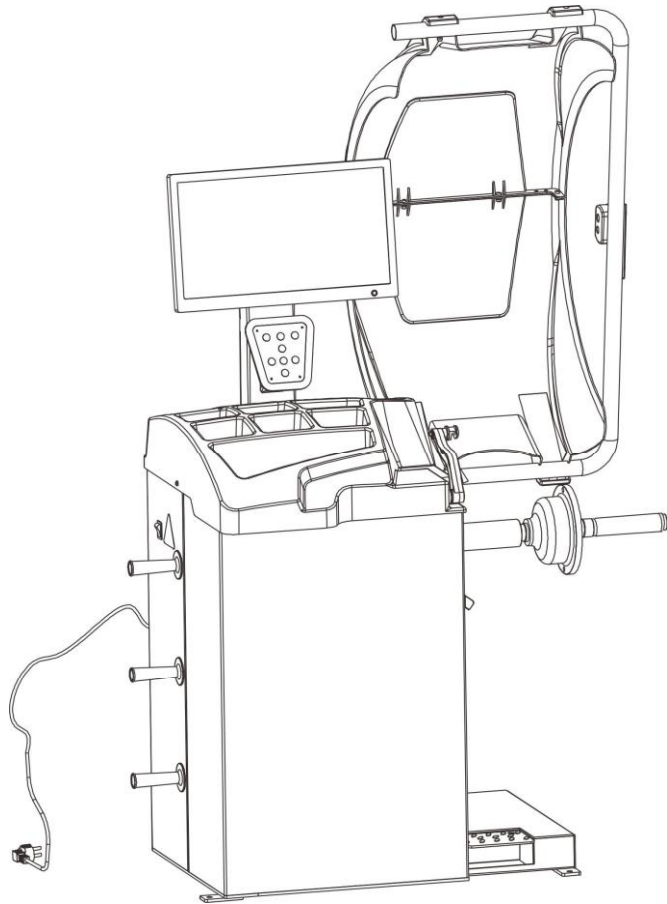

USER MANUAL



Warning

- This manual is a necessary part of the product. Please read carefully.
- Keep the manual for future reference when maintaining the machine.
- This machine may only be used for its designated purposes. Never use it for any other purpose.
- The manufacturer is not responsible for the damage incurred by improper use or use other than the intended purpose.

Precaution

- The equipment can only be operated by qualified personnel with special training. Modification to any components and parts or using the machine for other purposes without either obtaining the agreement from the producer or in violation of the instructions may lead to direct or indirect damage to the equipment.
- ★ **Install the equipment on stable ground to ensure accurate readings;** not on a wooden pallet or other unstable platforms.
- Keep the back panel 0.6m away from the wall for good ventilation. Enough room should be left on both sides for convenient operation.
- Do not place the equipment in an area with high temperature or moisture, or near the heating system, water tap, air-humidifier, or chimney.
- Avoid environments with excessive dust, ammonia, alcohol, thinners, or spraying binders.
- Keep anyone who is not operating the machine at a safe distance while it is in use.
- Use appropriate equipment, tools, and personal protective equipment, including safety glasses, earplugs, and work boots.
- Pay special attention to the marks on the machine.
- Do not touch or approach the moving parts by hand during operation.
- Do not remove, disable, or block any safety device.

Contents

1. General -----	1
2. Machine assembly -----	1
3. Controls and components -----	3
4. Indication and Use of the Wheel Balancer -----	6
5. Self-diagnoses/Machine Settings/Self-Calibration -----	11
6. Errors -----	18
7. OPT Function-----	20
8. Spare Parts List and Exploded Drawings -----	21

1. General

1.1. Technical data:

- Max wheel weight: 65kg
- Power: 0.2kW, 0.37kW
- Power supply: 110V, 220V – 240V, 50 – 60Hz
- Balancing accuracy: $\pm 1g$
- 8 balancing modes: DYN, ALU1, ALU2, ALU3, ALU4, ALU5, ALU-S, ALU-S2, Moto-1, Moto-2
- Balancing speed: 200 RPM
- Cycle time: 8s
- Rim diameter: 10" – 24" (256mm – 610mm)
- Sound pressure level during work cycle: <70 dB

1.2. Features:

- Distance and diameter values are recorded automatically
- ALU balancing mode may choose 6 o'clock or 12 o'clock position for weight placement
- Statistical and dynamic balancing, ALU-programs for alloy rims or special shapes
- Self-diagnoses, easy to find the problem and troubleshooting
- Suitable for steel and aluminum alloy rims

1.3. Working environment:

- Temperature: 5 – 50°C
- Height: $\leq 4000m$

2. Machine assembly

2.1. Unpack

Unpack the carton, check for any missing spare parts.

No.	Item	Qty
1	Width gauge	1
2	Conic No. 1	1
	Conic No. 2	1
	Conic No. 3	1
	Conic No. 4	1
3	Quick release nut	1
4	Thread hub	1
5	Bowl for quick nut	1
6	Pad for bowl	1
7	Balancing hammer	1
8	100g weight	1
9	Allen wrench	1

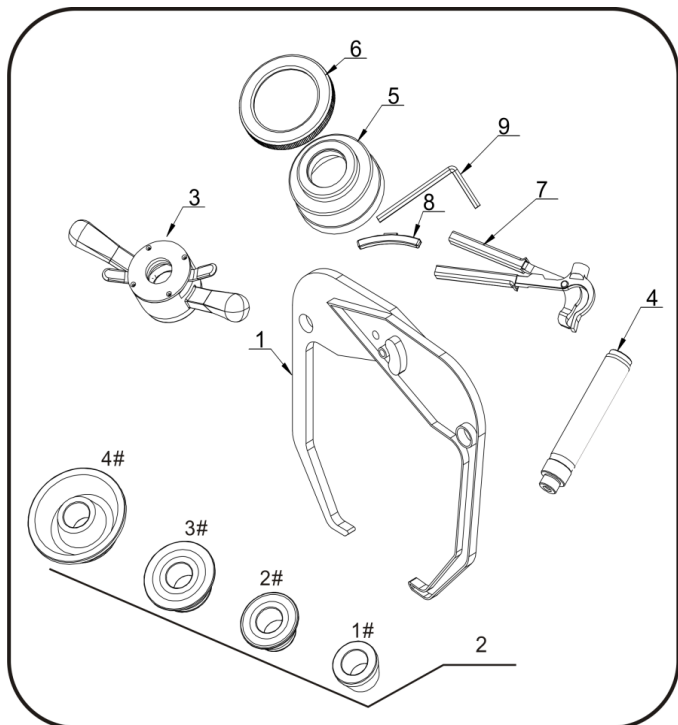

2.2. Install

- The equipment should be installed on the stable ground to ensure accurate readings. Do not install on wooden pallets or other platforms.
- Keep the back panel 0.6m away from the wall for good ventilation. Enough room should be left on both sides for convenient operation.

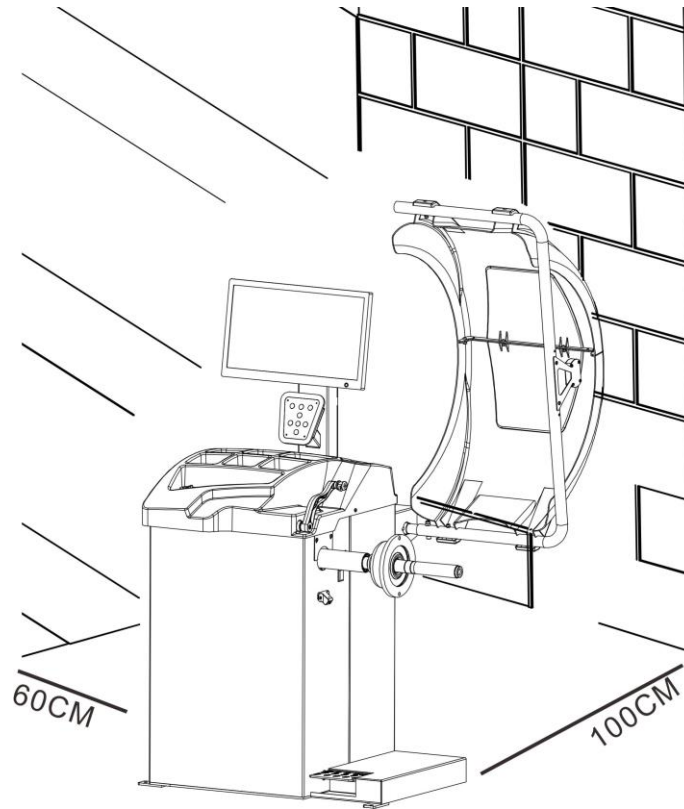

2.3. Secure and fix the wheel balancer to the floor by anchoring screws on the bottom.

2.4. Install adaptor

The wheel balancer is supplied complete with cone-type adaptor for fastening wheels with a central bore (see below picture).

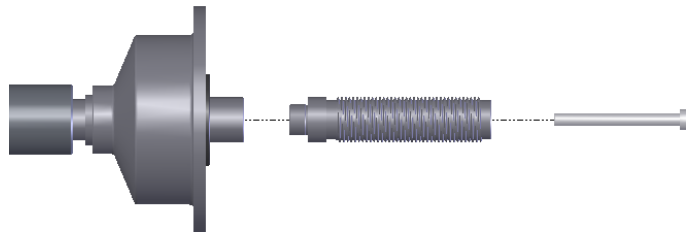

2.5. Install wheel

Clean wheel, remove any counterweights, and check tire pressure.

Select installation based on wheel type:



Standard-bore mounting

Main shaft > wheel >
suitable cone (small end toward inside) >
quick-release handle nut

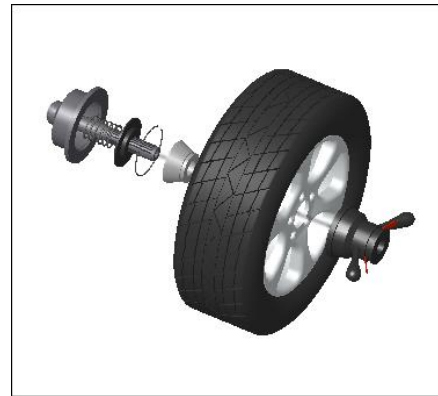

Recessed-bore mounting

Main shaft > wheel >
suitable cone (large end toward inside) >
quick-release handle nut

Note: You may support the wheel against a stationary object to help install the threaded hub. When installing or removing the wheel, do not allow it to slide on the shaft to avoid scratching the shaft surface.

3. Controls and components

No.	Item	Standard (S)/ Optional (O)
A	Switch	S
B	Cover with tool tray	S
C	Gauge head	S
D	Main shaft	S
E	Pedal breaker	S
F	Safe guard	S
G	Screen	S
H	Keyboard	S
J	Width Gauge	S
K	Laser	S

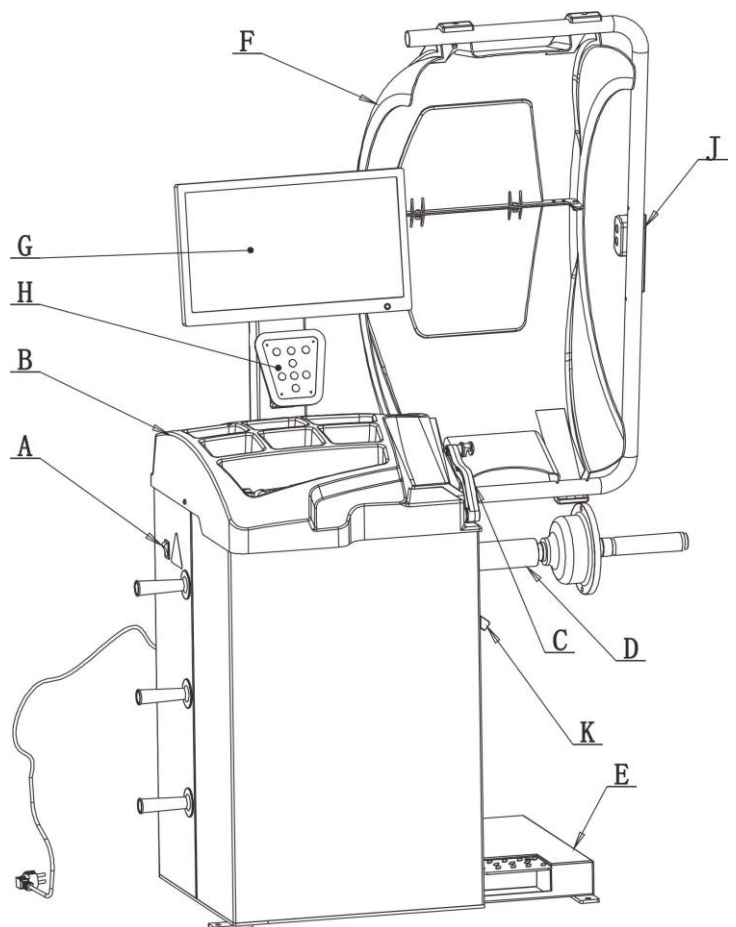



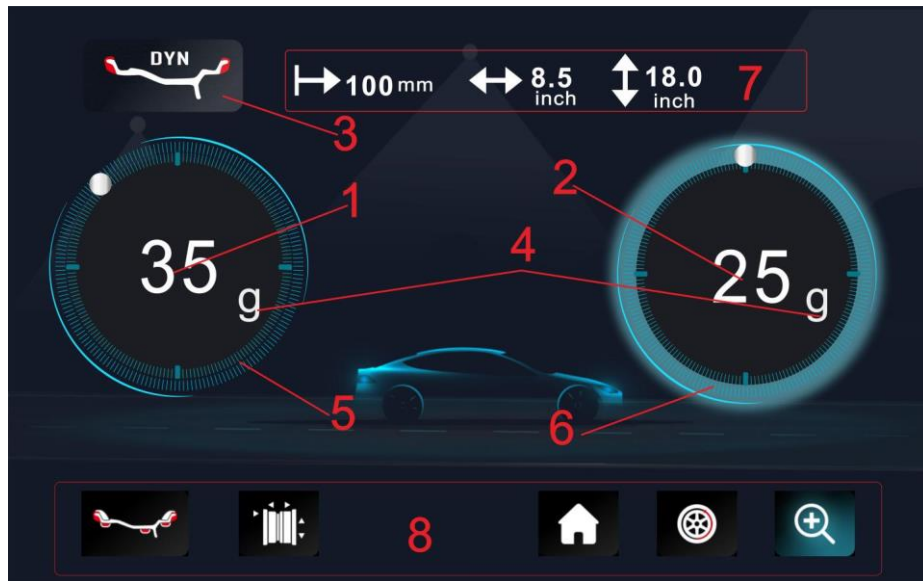

Screen (G)









- | | |
|-----------------------------|--|
| (1) Inner unbalance value | (5) Inside unbalance position indicator |
| (2) Outside unbalance value | (6) Outside unbalance position indicator |
| (3) Balancing Mode | (7) Illustrated unbalance position |
| (4) Operating Unit | (8) Function buttons |

MODE	INSIDE	ICON	OUTSIDE	OPERATION	WEIGHTS POSITION
Default	12 o'clock		12 o'clock	<ol style="list-style-type: none"> 1. Turn on machine. 2. Input a, b, and d values. 3. Start spin, wait to stop then add weights. 	Clip on weights on both sides of rim edge
ALU1	6 o'clock		6 o'clock	<ol style="list-style-type: none"> 1. Turn on machine. 2. Input a, b, and d values. 3. Press [◀] button, wait for light indicator. 4. Start spin, wait to stop then add weights. 	Add adhesive weights on the rim shoulder both sides
ALU2	12 o'clock		6 o'clock	<ol style="list-style-type: none"> 1. Turn on machine. 2. Input a, b, and d values. 3. Press [◀] button, wait for light indicator. 4. Start spin, wait to stop then add weights. 	Clip on weight on inside rim edge, add adhesive weight on outside rim shoulder
ALU3	6 o'clock		12 o'clock	<ol style="list-style-type: none"> 1. Turn on machine. 2. Input a, b, and d values. 3. Press [◀] button, wait for light indicator. 4. Start spin, wait to stop then add weights. 	Add adhesive weights on the rim shoulder both sides
ALU4	12 o'clock		12 o'clock	<ol style="list-style-type: none"> 1. Turn on machine. 2. Input a, b, and d values. 3. Press [◀] button, wait for light indicator. 4. Start spin, wait to stop then add weights. 	Clip on weight on inside rim edge, add adhesive weight on outside rim shoulder
ALU5	6 o'clock		12 o'clock	<ol style="list-style-type: none"> 1. Turn on machine. 2. Input a, b, and d values. 3. Press [◀] button, wait for light indicator. 4. Start spin, wait to stop then add weights. 	Add adhesive weight on inside rim shoulder, clip on weight on outside rim edge

ALU-S1	6 o'clock		6 o'clock	<ol style="list-style-type: none"> 1. Turn on machine. 2. Input aI, aE, and d values. 3. Start spin, wait to stop then add weights. 	Add adhesive weights on the two positions gauge head touch
ALU-S2	12 o'clock		6 o'clock	<ol style="list-style-type: none"> 1. Turn on machine. 2. Input aI, aE, and d values. 3. Start spin, wait to stop then add weights. 	Add adhesive weights on the two positions gauge head touch
Moto-1	12 o'clock		12 o'clock	<ol style="list-style-type: none"> 1. Turn on machine. 2. Input a, b, and d values. 3. Press [◀] button, wait for light indicator. 4. Start spin, wait to stop then add weights. 	Add adhesive weight
Moto-2	12 o'clock		12 o'clock	<ol style="list-style-type: none"> 1. Turn on machine. 2. Input a, b, and d values. 3. Press [◀] button, wait for light indicator. 4. Start spin, wait to stop then add weights. 	Add adhesive weights on the rim shoulder both sides

Keyboard Reference (H)

Icon	Function	Icon	Function
	Data key/ Menu confirmation		Choose/ Search for location
	Selection of "ALU" modes / Left click		Right click
	Start		Stop/Cancel/Brake



4. Indication and use of wheel balancer

4.1. DYN (Standard/Default) mode

4.1.1. Clean wheel, remove any counterweights, and check tire pressure. Select installation based on wheel type:



Standard-bore mounting

Main shaft > wheel >
suitable cone (small end toward inside) >
quick-release handle nut

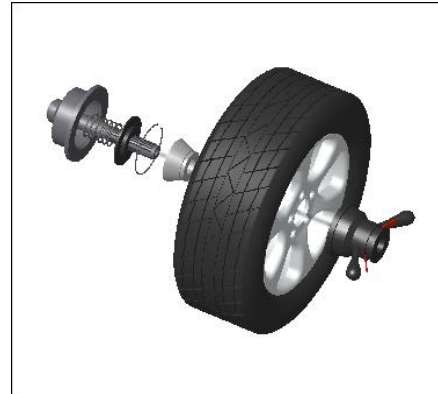



Recessed-bore mounting



Main shaft > wheel >
suitable cone (large end toward inside) >
quick-release handle nut



Note: You may support the wheel against a stationary object to help install the threaded hub. When installing or removing the wheel, do not allow it to slide on the shaft to avoid scratching the shaft surface.

4.1.2. Turn on the machine.

4.1.3. Input a, b, and d values:

● **set “a” value:** Move the gauge to the measuring position as illustrated in Figure 1. Hold the gauge in position for approximately 4 seconds until the value is stored, then return the gauge to position 0. (The value measured in automatic mode appears on the display). To set manually, press  then adjust with the  and  buttons.

● **set “b” value:** Set nominal diameter “b” marked on the rim or measure it using the **width gauge** (see Fig. 2a). Press , then  and  buttons to set manually. If the balancer has the optional **automatic width ruler**, let the gauge head touch the rim as seen in Fig. 2b. Hold it in place until a beep is heard, indicating successful memorization, then release the gauge.

● **set “d” value:** This is measured automatically at the same time as “a”. To enter manually, press , then  and  to set manually.

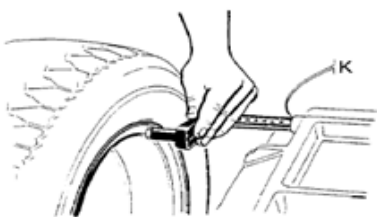

Fig. 1

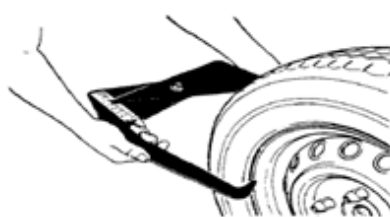

Fig. 2a

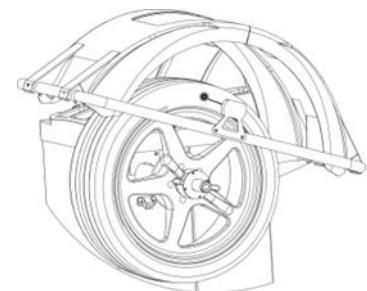
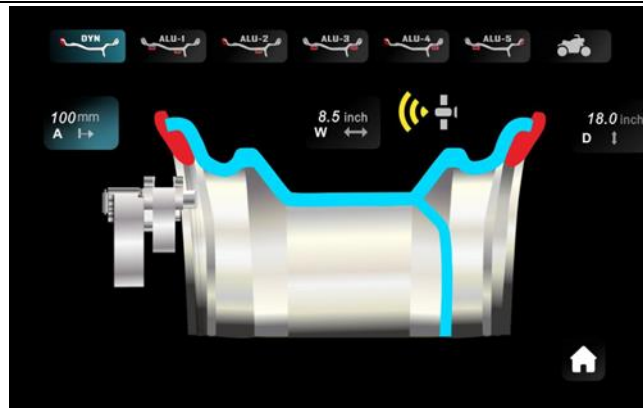







Fig. 2b



4.1.4. Put down the guard and press  to perform a measuring spin.

4.1.5. In a few seconds, the wheel accelerates to operating speed and begins measuring unbalance. When it stops, the values will display on instruments 1 and 3. Press , select , then press  to view the unbalance value within the threshold.

4.1.6. Press  until the right LED fully lights up. Clip weight on the 12 o'clock position (Fig. 3)

4.1.7. Press  until the left LED fully lights up. Clip weight on the 12 o'clock position (Fig. 4)

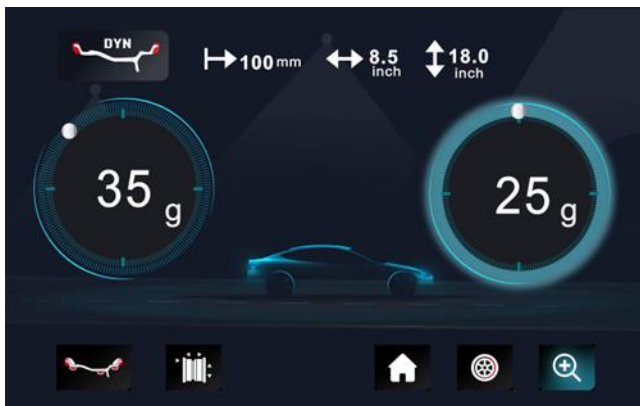

Fig. 3

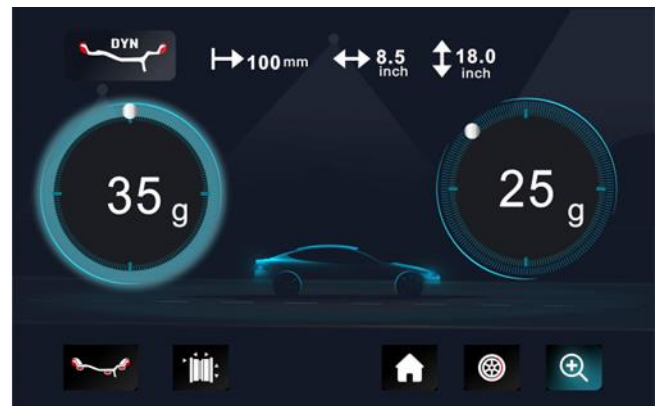

Fig. 4

4.1.8 After clipping the counterweights, close the guard. Press  to perform a balancing spin again, if the display shows 00 and 00, this means that balancing was successful (Fig. 5).

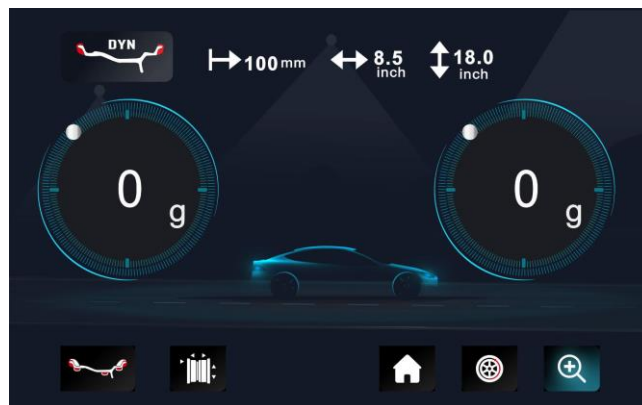



Fig. 5



4.2. ALU-1 mode

- ALU1, ALU2, ALU3, ALU4, and ALU5 have identical operation, only the position of where to add weights differ

4.2.1. Set a, b, and d values.

4.2.2. Press the  button until ALU1 indicator lights up.

4.2.3. Put down the guard and press  to perform a measuring spin.

4.2.4. In a few seconds, the wheel accelerates to operating speed and begins measuring unbalance. When it stops, the values will display on instruments 1 and 3. Press , select , then press  to view the unbalance value within the threshold.

4.2.5. Press  until the right LED fully lights up, indicating the correct angular position on where to mount the counterweights.. Clip weight on the 6 o'clock position (Fig. 6)

4.2.6. Press  until the left LED fully lights up, indicating the correct angular position on where to mount the counterweights.. Clip weight on the 6 o'clock position (Fig. 7)

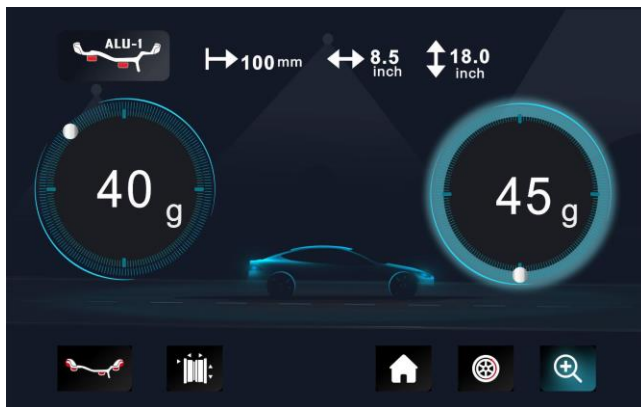

Fig. 6

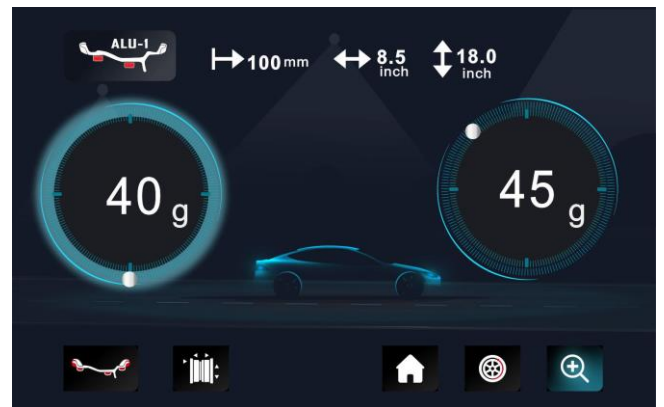

Fig. 7

4.2.7. After clipping the counterweights, close the guard. Press  to perform a balancing spin again, if the display shows 00 and 00, this means that balancing was successful (Fig. 8).

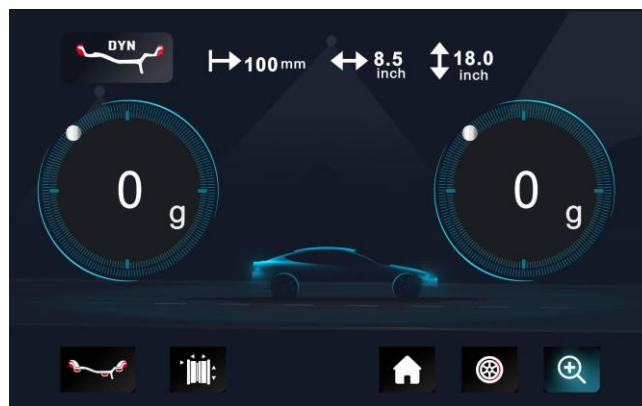

Fig. 8

4.3. ALU-S1 mode

This mode is used for special rims when ALU1/ALU2 cannot be used.

4.3.1. Input aI, aE, and d values.











- Set “aI”: Pull the gauge out and let its head contact the FI position for 4s. To set manually, press  then adjust with the  and  buttons.
- Set “aE”: Pull the gauge out and let its head contact the FE position for 4s. To set manually, press  then adjust with the  and  buttons.
- Set “dI”: Measure the inner rim diameter. To set manually, press  then adjust with the  and  buttons.



Fig. 9

4.3.2. Put down the guard and press  to perform a measuring spin.

4.3.3. Press  until the right LED fully lights up. Add weight on 6 o'clock position (Fig. 10).

4.3.4. Press  until the left LED fully lights up. Add weight on 6 o'clock position (Fig. 11).

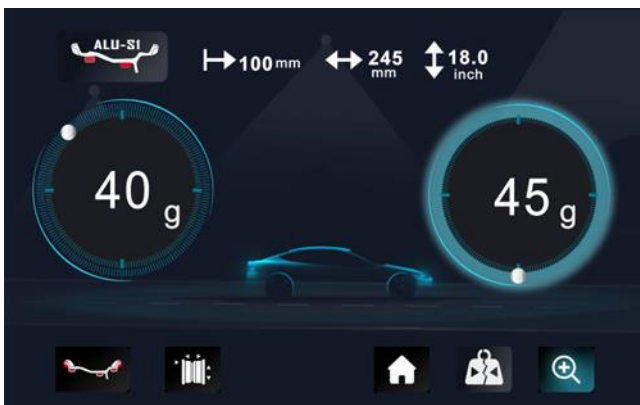

Fig. 10

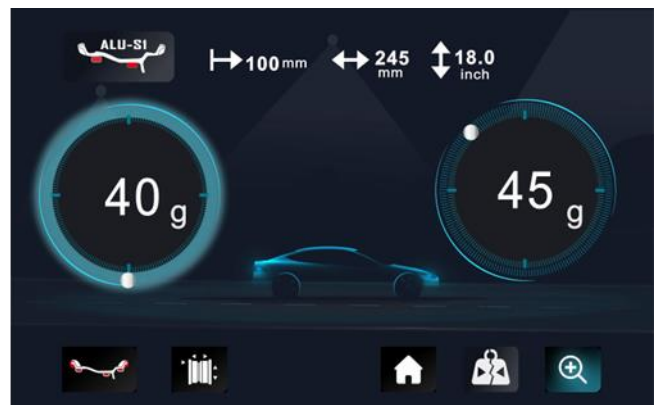



Fig. 11

4.2.7. After clipping the counterweights, close the guard. Press  to perform a balancing spin again, if the display shows 00 and 00, this means that balancing was successful (Fig. 12).

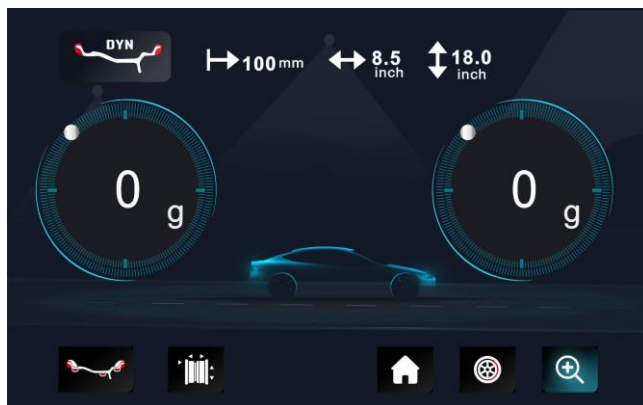
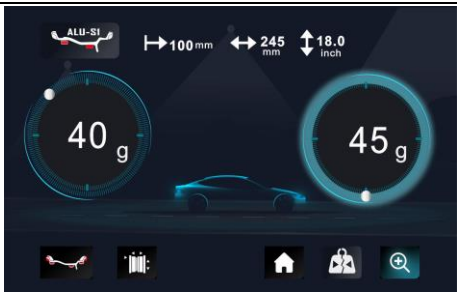



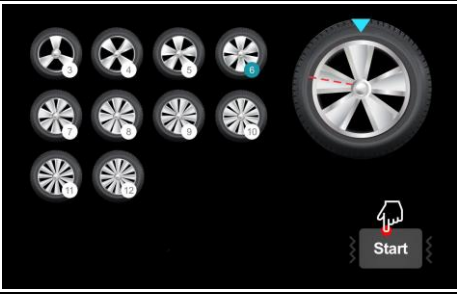



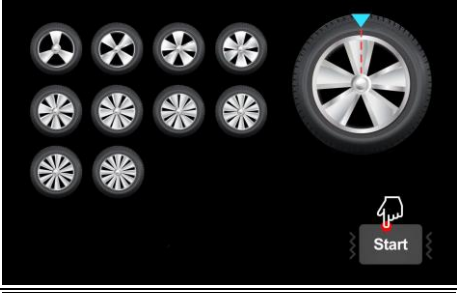











Fig. 12







4.4 ALU-S1 split function

Note: Only ALU-S mode can use this function and operator must be experienced.

#	DISPLAY	STEPS
1		With ALU-s active, press  key, select  , and then press  .
2		Use the  and  buttons to input chosen spoke, then press  .
3		Rotate wheel (either direction) until next spoke aligns with the 12 o'clock position, then press  .
4		Press the  key until the outer imbalance SP1 LED fully lights up.

5		<p>Press the  key until the outer imbalance SP2 LED fully lights up.</p>
6		<p>Press the  key until the inner imbalance indicator light fully lights up.</p>
7		<p>Put down the guard and press  to perform a measuring spin. If the display shows 00 and 00, this means that balancing was successful</p>

5. MACHINE SETTING AND SELF-CALIBRATION

- Select the , then press  key to enter the program.
- There are 11 main menus (Fig. 13). Use , , and  keys for selection. Press  to exit.

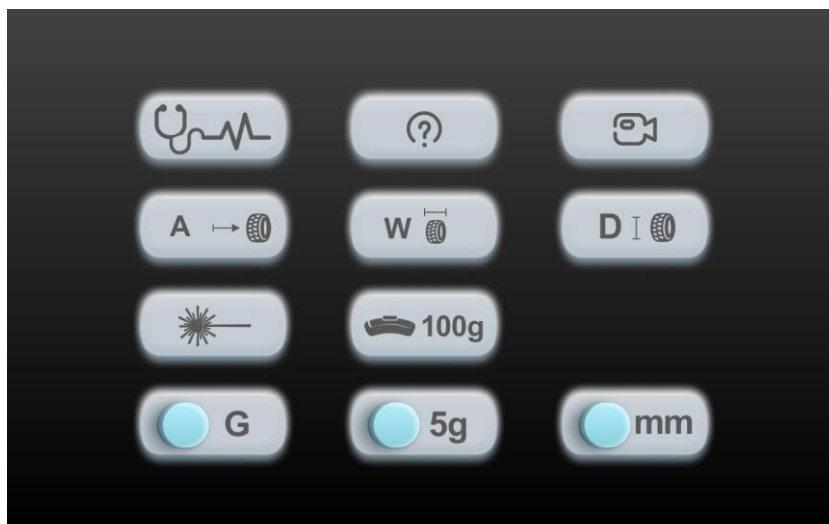

Fig. 13

5.1. Self Diagnosis

- Do the following sequence: Press , , and 

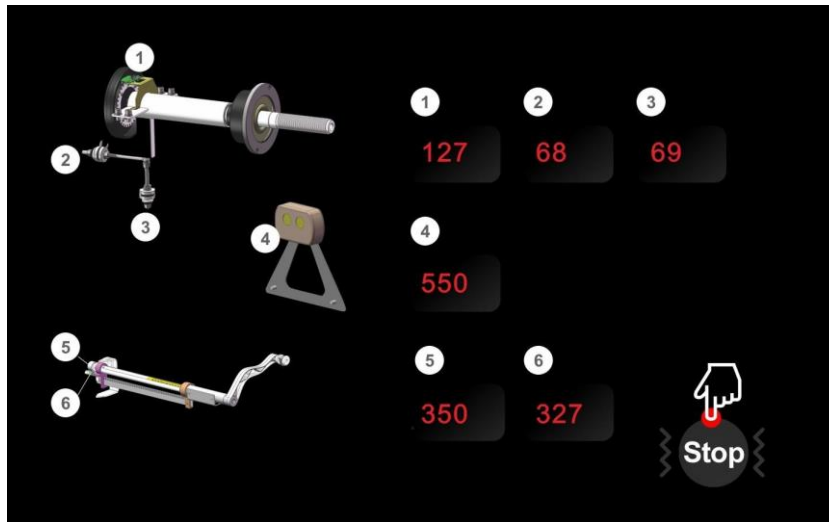

Fig. 14

#	Function	NORMAL FUNCTION
1	Position pickup board	POS changes value from 0 – 127.
2	Pressure sensor	Press main shaft by hand. The displays should toggle between 4X – 4X and 6X – 6X.
3	Pressure sensor	Press main shaft by hand. The displays should toggle between 4X – 4X and 6X – 6X.
4	Width potentiometer	Covering the sensor with your hand should cause the value to change from 0 – 600.
5	Diameter potentiometer	Turning the ruler to another direction causes the value to change, ranging from 327 – 350.
6	Distance potentiometer	Pulling the gauge out causes the value to change from 327 – 340.

5.2. Instructions







- Do the following sequence: Press , , and 

5.3. Video

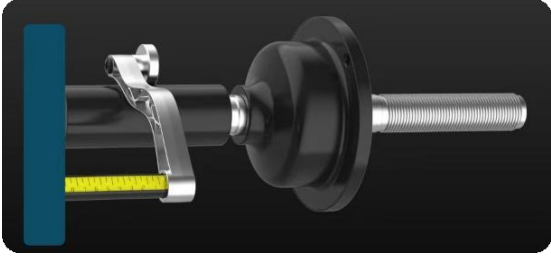

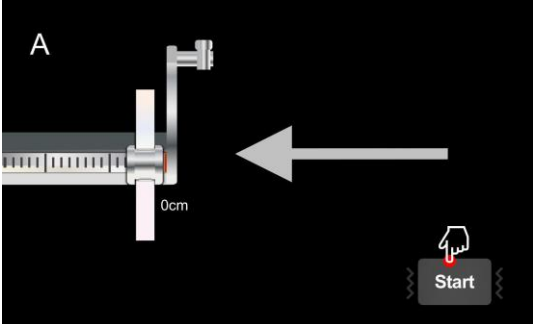
- Do the following sequence: Press , , and 

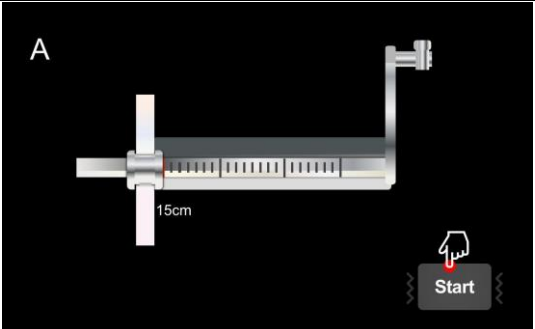

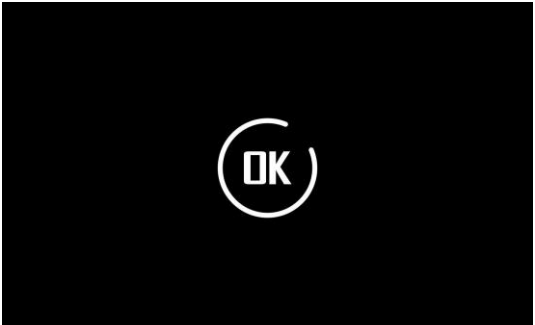
5.4. Rim Distance Gauge Calibration

- Do the following sequence: Press , , and .

#	DISPLAY	STEPS
1		Rotate the gauge so the scale rests against the main shaft, then press  .
2		Pull the distance gauge out to the “0cm” position and hold, then press  .
2		Pull the distance gauge out to the “15cm” position and hold, then press  .
3		Calibration finished.





5.5. Width gauge radar calibration

- Do the following sequence: Press , , and .
- No tires need to be installed.

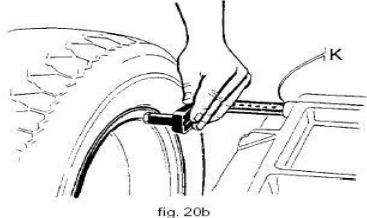
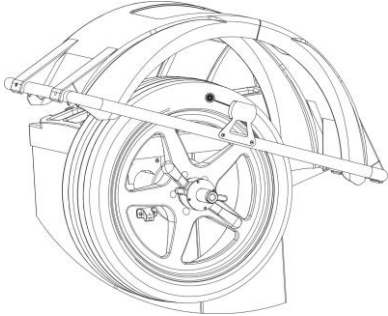

#	DISPLAY	STEPS
1		Keep the shield in position.
2		Calibration finished.







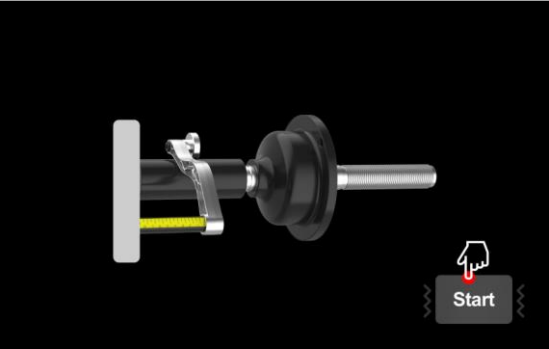

5.5.1. Width compensation

- This procedure requires a tire installation with a known tire width.

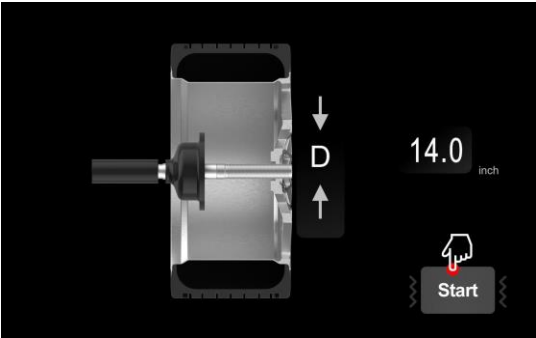
#	DISPLAY	STEPS
1		Enter the b value (nominal tire width).
2		Aim the radar sensor at the tire shoulders to confirm the measurement zone.
3	Press the  key with the  OR  key at the same time to modify the known tire width. Put down the key to save automatically.	



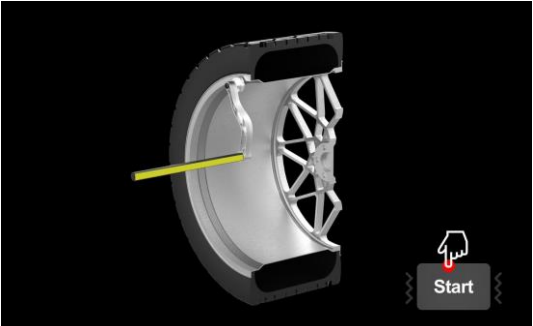



5.6. Diameter Gauge Calibration

- Do the following sequence: Press , , and .
- A tire must be installed to perform this function.

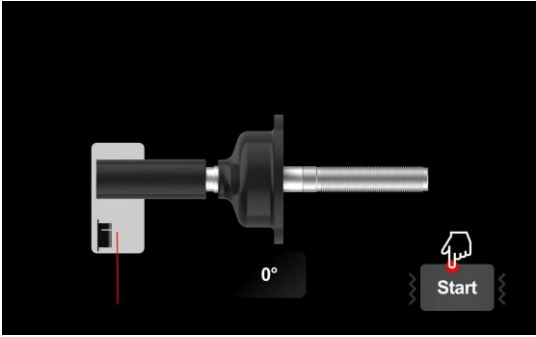

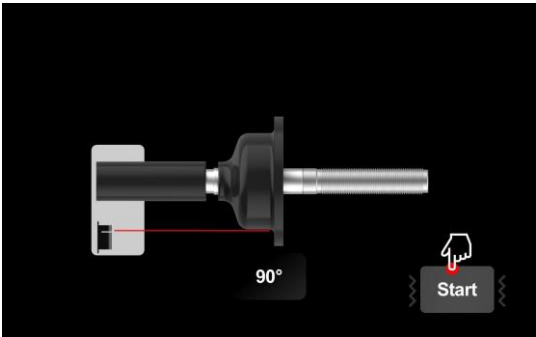
#	DISPLAY	STEPS
1		<p>Slide the diameter ruler until its sleeve touches the transmission shaft and hold, then press .</p>
2		<p>Enter diameters by using the  and  keys. Then press  key to confirm.</p>
3		<p>Move the gauge until it touches the edge of rim and keep it still. Press  key to confirm.</p>
4		<p>Calibration finished.</p>

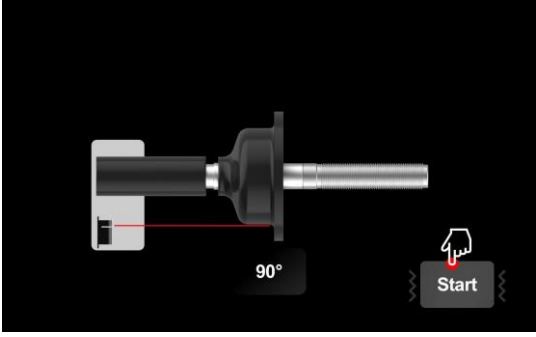





5.7. Laser Calibration

- Do the following sequence: Press , , and .
- This function can only be performed if the wheel balancer has a laser.





#	DISPLAY	STEPS
1		<p>Press  key to start.</p>
2		<p>Adjust the laser using the  and  keys.</p>
3		<p>Press  key to confirm adjustment.</p>
4		<p>Calibration finished.</p>

5.8. Self-Calibration





- Do the following sequence: Press , , and .
- Perform this function whenever you think the balancer is not accurate.
- Ensure that the 100g weight to be used is accurate.

#	DISPLAY	STEPS
1		Install a medium sized wheel (14" – 18") which can use a clip-on weight. Set a, b, and d values. Put down guard then press  to perform a balancing spin.
2		Open the guard and clip a 100g weight on the outside 12 o'clock position. Close guard and press  to perform a balancing spin again.
3		Open the guard and clip a 100g weight on the inside 12 o'clock position. Close guard and press  to perform a balancing spin again.
4		Calibration finished.





5.9. Unit of Weight

- Do the following sequence: Press , then .
- Press the  key to modify between  (grams) and  (ounces).

5.10. Unbalance Display Threshold



- Do the following sequence: Press , then .
- Press the  key to modify between  (5g) and  (10g).



5.11. Measurement units (mm/inch)

- Do the following sequence: Press , then .
- Press the  key to modify between  (millimeters) and  (inches).

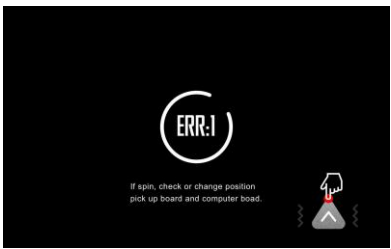
6. Errors

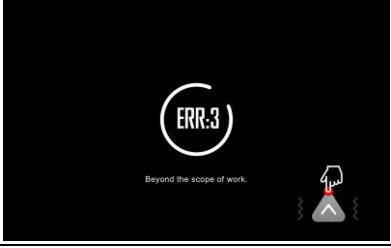
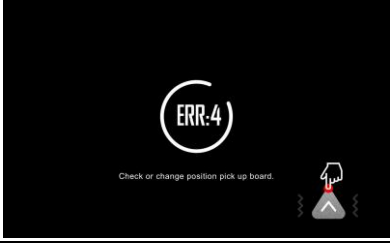

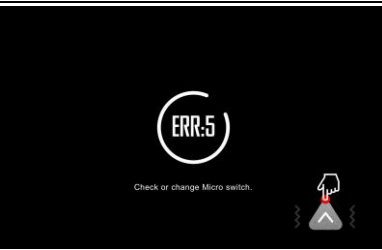
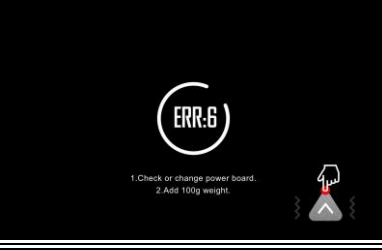
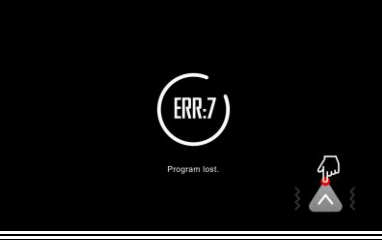
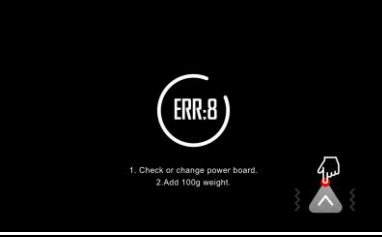
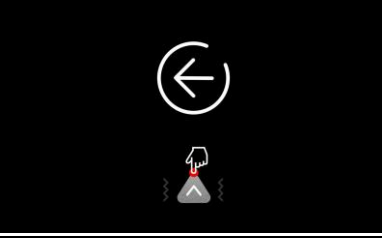







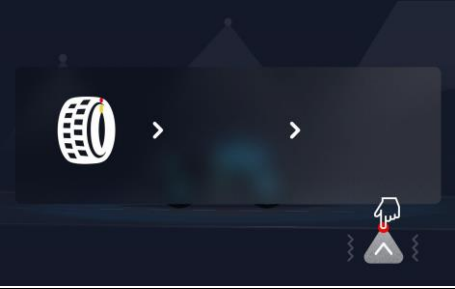

The equipment can detect various abnormal conditions during operation. If any of these occur, stop the machine immediately. Use the guide below to identify the cause and apply the recommended solution. If the error persists, consult the supplier.

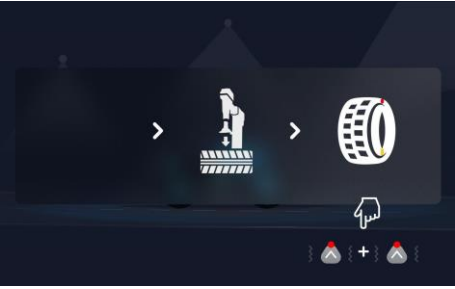

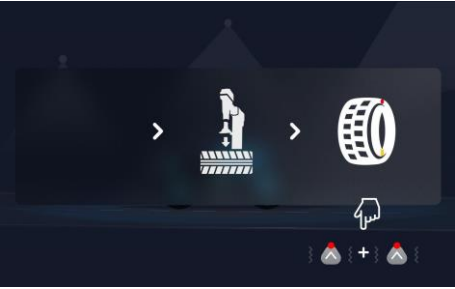

No.	Errors	Reasons	Solution
1		<ol style="list-style-type: none"> 1. No spin. 2. Shaft spin. 	<ol style="list-style-type: none"> 1. If there is no spin, check or replace the power board. 2. If it spins but error remains, check or change the position-pickup board and computer board. 3. Re-align or tighten position-pickup board bracket.
2		<ol style="list-style-type: none"> 1. No wheel attached or wheel is not locked tightly. 2. Position-pickup board problem. 	<ol style="list-style-type: none"> 1. Lock tightly. 2. Check or replace position-pickup board.
3		<ol style="list-style-type: none"> 1. Insufficient tire pressure. 2. Wheel distortion. 	<ol style="list-style-type: none"> 1. Inflate tire to proper pressure. 2. Inspect or replace the damaged wheel.
4		<ol style="list-style-type: none"> 1. Position-pickup board problem. 2. Computer board problem. 	<ol style="list-style-type: none"> 1. Check or change position-pickup board. 2. Check or change computer board.

5		<ol style="list-style-type: none"> 1. Micro-switch problem. 2. Computer board problem. 	<ol style="list-style-type: none"> 1. Check or change micro-switch. 2. Check or change computer board.
6		<ol style="list-style-type: none"> 1. Power board problem. 2. Computer board problem. 	<ol style="list-style-type: none"> 1. Check or change power board. 2. Check or change computer board.
7		<ol style="list-style-type: none"> 1. Program lost. 2. Computer board problem. 	<ol style="list-style-type: none"> 1. Perform self-calibration. 2. Check or change computer board.
8		<ol style="list-style-type: none"> 1. 100g weight not added during self- calibration. 2. Computer board problem. 3. Power board problem. 	<ol style="list-style-type: none"> 1. Add 100g weight as instructed. 2. Check or change computer board. 3. Check or change power board.
9		Emergency Stop.	Return.
10		Data Protection	<ol style="list-style-type: none"> 1. Contact vendor to unlock. 2. Update data.

7. OPT function

Use this function when initial unbalance reading is unusually high. Operator must be experienced.

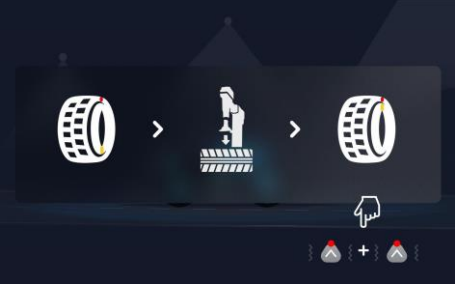
#	DISPLAY	STEPS
1		<p>Install wheel and input a, b, and d values. Press the  key, select , and then press .</p>
2		<p>Close guard and press  to perform a balancing spin.</p>
3		<p>Using the tire changer, rotate the tire 180 ° on the rim. Then, press .</p>
4		<p>Close guard and press  to perform a balancing spin again.</p>
5		<p>Press the  button to rotate the wheel until four indicators lit up (two on both sides, the dark spot in the left side picture).</p> <p>Mark the tire with a chalk as position “C”.</p>

6		<p>Press  to rotate the wheel again until two indicators lit up (one on both sides, the dark spot in the left side picture).</p> <p>Mark this position as “D” on the rim with chalk</p>
7		<p>With the help of tire changer, rotate the tire on the rim, aligning the “C” and “D” marks, similar to the reference figure on the right.</p>
8	<p>If unbalance is less than before, OPT function has succeeded.</p>	<p>Close guard and press  to perform a balancing spin again.</p>

10. Spare parts list and Exploded drawings